



FICHE D' HOMOLOGATION CONFORME A L' ANNEXE J DU CODE SPORTIF INTERNATIONAL
HOMOLOGATION FORM IN ACCORDANCE WITH APPENDIX J OF THE INTERNATIONAL SPORTING CODE

Homologation valable à partir du Homologation valid as from 01 MARS 1995

A) Voiture vue de 3/4 avant Car seen from 3/4 front



B) Voiture vue de 3/4 arrière Car seen from 3/4 rear



1. GENERALITES / GENERAL

101. Constructeur ALFA ROMEO Manufacturer

102. Dénomination(s) commerciale(s) - Modèle et type 155 (M. Y. 1995) Commercial name(s) - Model and type

104. Mode de construction : a) Mode : séparée monocoque Type of car construction : Type : separate unitary construction

b) Matériau du châssis / coque acier - acciaio Material of chassis / bodyshell

105. Nombre de volumes 3 Number of volumes

106. Nombre de places 5 Number of places

© FISA - FC - 1994 - 048.01.FB.11.94



FEDERATION INTERNATIONALE DE L' AUTOMOBILE 8, Place de la Concorde, 8 75008 PARIS

A9) Coque vue de 3/4 avant, sans portes, capots, etc.
 Bodyshell seen from 3/4 front without doors, lids, etc.

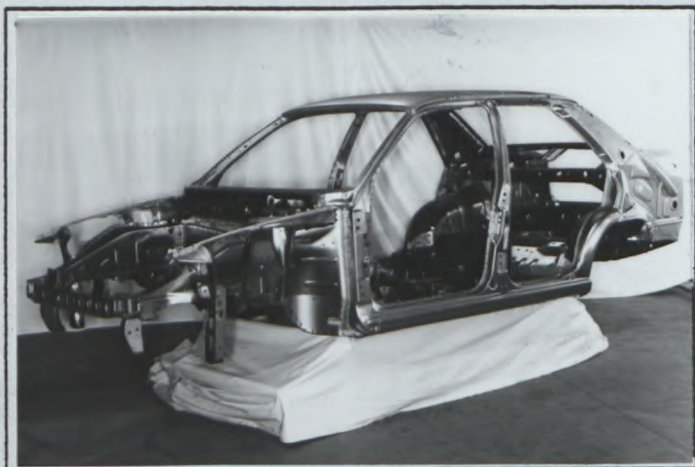

A10) Coque vue de 3/4 arrière, sans portes, capots, etc.
 Bodywork seen from 3/4 rear without doors, lids, etc.



2. DIMENSIONS, POIDS / DIMENSIONS, WEIGHT

202. Longueur hors-tout 4443 mm +/- 1 %
 Overall length

203. Largeur hors-tout 1732 mm +/- 1 %
 Overall width

Endroit de mesure aile avant - passaruote anteriore
 Where measured

204. Largeur de carrosserie 1732 mm +/- 1 %
 Width of bodywork

a) A la hauteur de l'axe avant 1732 mm +/- 1 %
 At front axle

b) A la hauteur de l'axe arrière 1705 mm +/- 1 %
 At rear axle

206. Empattement 2540 mm +/- 1 %
 Wheelbase

209. Porte-à-faux 960 mm +/- 1 %
 Overhang

a) Avant 960 mm +/- 1 %
 Front

b) Arrière 943 mm +/- 1 %
 Rear

210. Distance "G" (volant - paroi de séparation arrière) 1650 mm
 Distance "G" (steering wheel - rear bulkhead)

© FISA - FC - 1994 - 048.01.FB.11.94

**FEDERATION INTERNATIONALE
 DE L'AUTOMOBILE**
 8, Place de la Concorde, 8
 75008 PARIS

Marque ALFA ROMEO
 Make _____

Modèle 155 (M. Y. 1995)
 Model _____

ST - 009

4. CIRCUIT DE CARBURANT / FUEL CIRCUIT

401. Réservoir : au dessous de plancher et de compartiment bagages
 Fuel tank : soito il pavimento ed il vano bagagli
 b) Emplacement
 Location _____

6. TRANSMISSION / POWER TRAIN

601. Roues motrices : avant

oui	non
yes	no

arrière

oui	non
yes	no

 Driven wheels : front

oui	non
yes	no

rear

oui	non
yes	no

603. Boîte de vitesses : a1) Emplacement dans l'empattement

moitié avant	moitié arrière
front half	rear half

 Gearbox : Location in wheelbase

XII) CHAÎNE CINÉMATIQUE (4 roues motrices) / KINEMATIC TRAIN (4 wheel drive):

Marque ALFA ROMEO
MakeModèle 155 (M. Y. 1995)
Model

ST - 009

Modifications nécessaires pour passer d'une version 2 roues motrices (au moins 2500 exemplaires) à une version 4 roues motrices (au moins 2500 exemplaires) / Modifications necessary in order to go from a 2-wheel drive version (at least 2500 cars) to a 4-wheel drive version (at least 2500 cars)

FEDERATION INTERNATIONALE
DE L'AUTOMOBILE
8, Place de la Concorde, 8
75008 PARIS

7. SUSPENSION / SUSPENSION

701. Généralités General	Avant / Front	Arrière / Rear								
	Mc. PHERSON	bras tires - bracci tirati								
a) Type de suspension Type of suspension										
702. Ressorts hélicoïdaux Helicoïdal springs	<table border="1"> <tr><td><input checked="" type="checkbox"/> oui</td><td><input type="checkbox"/> non</td></tr> <tr><td><input checked="" type="checkbox"/> yes</td><td><input type="checkbox"/> no</td></tr> </table>	<input checked="" type="checkbox"/> oui	<input type="checkbox"/> non	<input checked="" type="checkbox"/> yes	<input type="checkbox"/> no	<table border="1"> <tr><td><input checked="" type="checkbox"/> oui</td><td><input type="checkbox"/> non</td></tr> <tr><td><input checked="" type="checkbox"/> yes</td><td><input type="checkbox"/> no</td></tr> </table>	<input checked="" type="checkbox"/> oui	<input type="checkbox"/> non	<input checked="" type="checkbox"/> yes	<input type="checkbox"/> no
<input checked="" type="checkbox"/> oui	<input type="checkbox"/> non									
<input checked="" type="checkbox"/> yes	<input type="checkbox"/> no									
<input checked="" type="checkbox"/> oui	<input type="checkbox"/> non									
<input checked="" type="checkbox"/> yes	<input type="checkbox"/> no									
703. Ressorts à lames Leaf springs	<table border="1"> <tr><td><input type="checkbox"/> oui</td><td><input checked="" type="checkbox"/> non</td></tr> <tr><td><input type="checkbox"/> yes</td><td><input checked="" type="checkbox"/> no</td></tr> </table>	<input type="checkbox"/> oui	<input checked="" type="checkbox"/> non	<input type="checkbox"/> yes	<input checked="" type="checkbox"/> no	<table border="1"> <tr><td><input type="checkbox"/> oui</td><td><input checked="" type="checkbox"/> non</td></tr> <tr><td><input type="checkbox"/> yes</td><td><input checked="" type="checkbox"/> no</td></tr> </table>	<input type="checkbox"/> oui	<input checked="" type="checkbox"/> non	<input type="checkbox"/> yes	<input checked="" type="checkbox"/> no
<input type="checkbox"/> oui	<input checked="" type="checkbox"/> non									
<input type="checkbox"/> yes	<input checked="" type="checkbox"/> no									
<input type="checkbox"/> oui	<input checked="" type="checkbox"/> non									
<input type="checkbox"/> yes	<input checked="" type="checkbox"/> no									
704. Barres de torsion Torsion bars	<table border="1"> <tr><td><input checked="" type="checkbox"/> oui</td><td><input type="checkbox"/> non</td></tr> <tr><td><input checked="" type="checkbox"/> yes</td><td><input type="checkbox"/> no</td></tr> </table>	<input checked="" type="checkbox"/> oui	<input type="checkbox"/> non	<input checked="" type="checkbox"/> yes	<input type="checkbox"/> no	<table border="1"> <tr><td><input checked="" type="checkbox"/> oui</td><td><input type="checkbox"/> non</td></tr> <tr><td><input checked="" type="checkbox"/> yes</td><td><input type="checkbox"/> no</td></tr> </table>	<input checked="" type="checkbox"/> oui	<input type="checkbox"/> non	<input checked="" type="checkbox"/> yes	<input type="checkbox"/> no
<input checked="" type="checkbox"/> oui	<input type="checkbox"/> non									
<input checked="" type="checkbox"/> yes	<input type="checkbox"/> no									
<input checked="" type="checkbox"/> oui	<input type="checkbox"/> non									
<input checked="" type="checkbox"/> yes	<input type="checkbox"/> no									

705. Autre type de suspension : *Voir description sur fiche additionnelle*
 Other type of suspension : *See description on additional form*

707. Amortisseurs : Shock absorbers :	Avant / Front	Arrière / Rear
	<u>1</u>	<u>1</u>

T) Train avant complet déposé
 Complete dismantled front axle



U) Train arrière complet déposé
 Complete dismantled rear axle

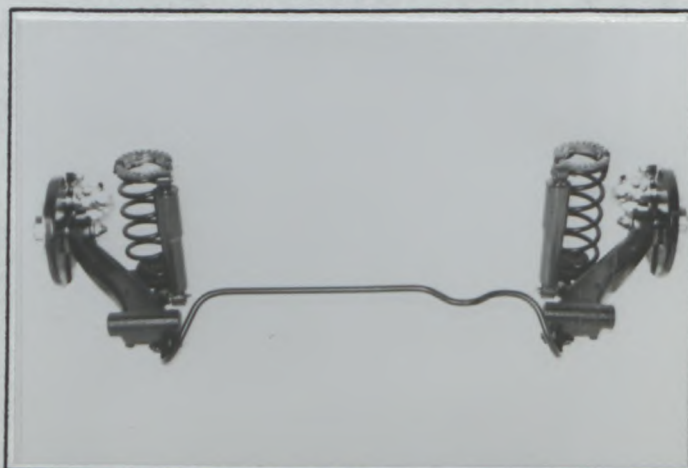

8. TRAIN ROULANT / RUNNING GEAR

804. Direction : Steering :	Avant / Front	Arrière / Rear
	<u>à cremaillere - a cremagliera</u>	_____

**FEDERATION INTERNATIONALE
 DE L'AUTOMOBILE**
 8, Place de la Concorde, 8
 75008 PARIS

9. CARROSSERIE / BODYWORK

X) Tableau de bord
 Dashboard



902. Extérieur :
 Exterior :

a) Nombre de portes 4
 Number of doors _____

b) Hayon
 Tailgate

<input checked="" type="checkbox"/>	<input type="checkbox"/>
oui yes	non no

Avant / Front	Arrière / Rear
c) Matériau des portières Door material	tole d' acier lamiera di acciaio
d) Matériau du capot avant Front bonnet material	tole d' acier lamiera di acciaio

tole d' acier
lamiera di acciaio

e) Matériau du capot arrière / ~~hayon~~
 Rear bonnet / ~~tailgate material~~

tole d' acier
lamiera di acciaio

f) Matériau de la carrosserie
 Bodywork material

tole d' acier - lamiera di acciaio

h) Matériau de lunette arrière
 Rear window material

verre de sureté
vetro di sicurezza

i) Matériau des glaces de custode
 Rear quarter window material

verre de sureté
vetro di sicurezza

Avant / Front	Arrière / Rear
k) Matériau des vitres latérales Side window material	verre de sureté vetro di sicurezza
l) Matériau du pare-choc Material of bumper	poliuretane renforcé poliuretano rinforzato

XIII) PARTIES DE CARROSSERIE SYNTHETIQUES / SYNTHETIC PARTS OF THE BODY :

9. CARROSSERIE - CARROZZERIA

902. Extérieur - Esterno

- Parties en plastique de la voiture

(indiquées des flèches)

Parti in plastica della vettura

(indicate dalle frecce)

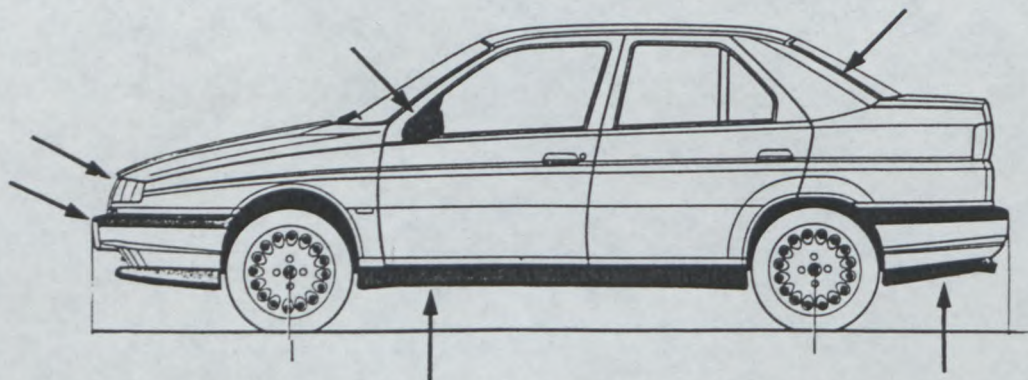

INFORMATIONS COMPLEMENTAIRES / COMPLEMENTARY INFORMATION :



Homologation No
ST - 009

Groupes **A/B/N/T1/** Supertourisme
Group **Supertouring**

Extension No

CERTIFICAT DE DIMENSIONS INTERIEURES
CERTIFICATE FOR INTERIOR DIMENSIONS

Véhicule: Constructeur ALFA ROMEO Modèle et type 155 (M. Y. 1995)
Vehicle: Manufactureur _____ Model and type _____

Dimensions intérieures comme définies par le Règlement d'Homologation
Interior dimensions as defined by the Homologation Regulations

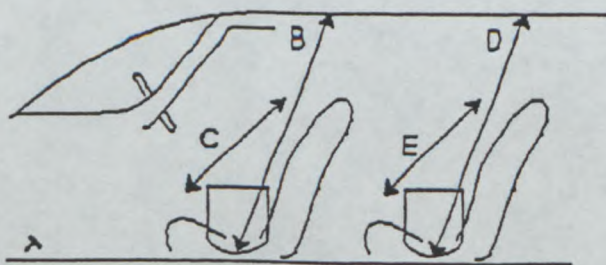

B	(Hauteur sur sièges avant) (Height above front seats)	<u>940</u> mm
C	(Largeur aux sièges avant) (Width at front seats)	<u>1345</u> mm
D	(Hauteur sur sièges arrière) (Height above rear seats)	<u>935</u> mm
E	(Largeur aux sièges arrière) (Width at rear seats)	<u>1337</u> mm

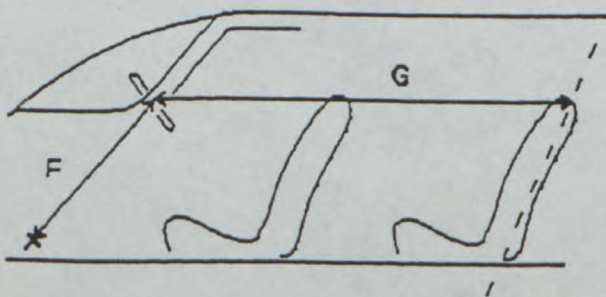

F	(Volant - Pédale de frein) (Steering wheel - Brake pedal)	<u>660</u> mm
G	(Volant - paroi de séparation arrière) (Steering wheel - rear bulkhead)	<u>1650</u> mm
H	H = F + G =	<u>2310</u> mm

**FEDERATION INTERNATIONALE
DE L'AUTOMOBILE**
8, Place de la Concorde, 8
75008 PARIS



FEDERATION INTERNATIONALE
DE L'AUTOMOBILE

Homologation No

ST - 009

Groupe
Group

A/B/N/T1 / Supertourisme
Supertouring

Extension No

01/01VO

FICHE D'EXTENSION D'HOMOLOGATION
FORM OF HOMOLOGATION EXTENSION

- ES Evolution sportive du type / Sporting evolution of the
- ET Evolution normale du type / Normal evolution of the
- VF Variante de fourniture / Supply variant
- VO Variante option / Option variant
- ER Erratum / Erratum

Véhicule: Constructeur
Vehicle: Manufactureur

ALFA ROMEO

Modèle et type
Model and type

155 (M. Y. 1995)

01 MARS 1995

Homologation valable à partir du
Homologation valid as from

Page ou ext. Page or ext.	Article Article	Description Description
	9.	CARROSSERIE - CARROZZERIA
	901.	Intérieur - Interno d) Sièges Sedili - Solution, validée alternativement pour les sièges AV droite et gauche, des points d'attaques et supports Soluzione, valida alternativamente per i sedili anteriore destro e sinistro, dei punti d'attacco e supporti Voir photo - Vedi foto 1 /95 - 2 /95
	902.	Extérieur - Esterno - Spoiler AV Spoiler Ant. Voir photo - Vedi foto 3 /95 - Spoiler AR Spoiler Post. Voir photo - Vedi foto 4 /95



FEDERATION INTERNATIONALE
DE L'AUTOMOBILE
8, Place de la Concorde, 8
75008 PARIS

Marque
Make

ALFA ROMEO

Modèle
Model

155 (M. Y. 1995)

ST - 009

Extension No

01/01 V0

PHOTO No 1 /95

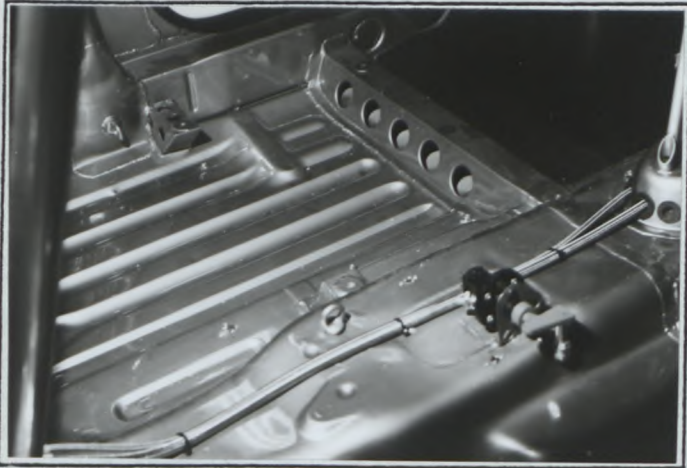

PHOTO No 2 /95

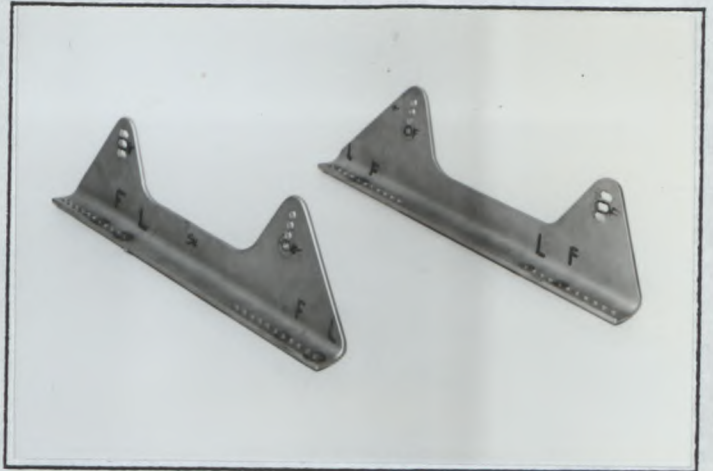

PHOTO No 3 /95



PHOTO No 4 /95



PHOTO No

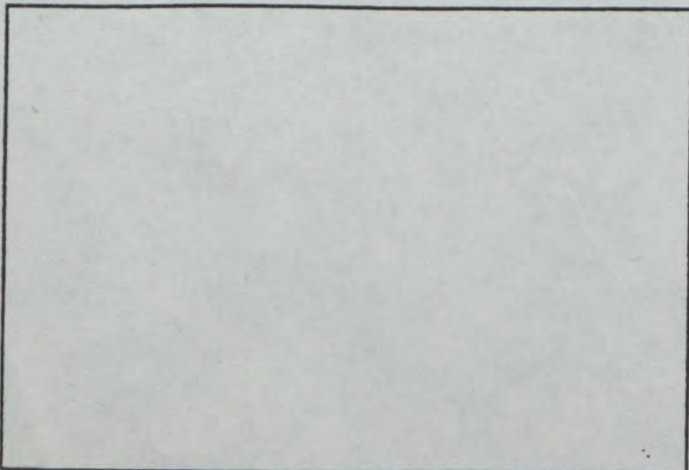
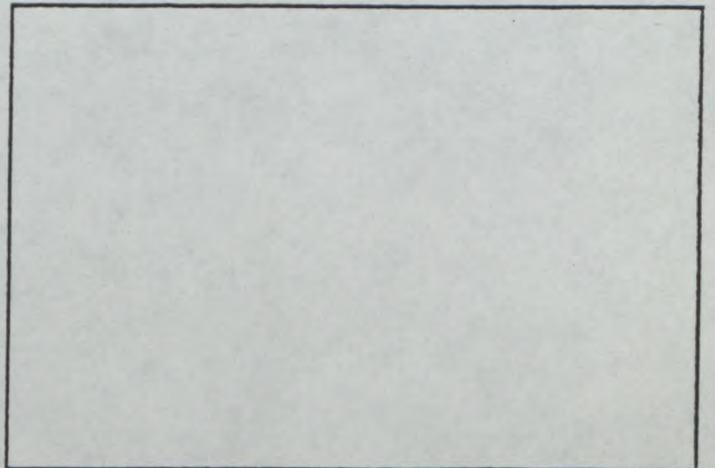

PHOTO No



FEDERATION INTERNATIONALE
DE L'AUTOMOBILE
8, Place de la Concorde, 8
75008 PARIS



FEDERATION INTERNATIONALE DE L'AUTOMOBILE

Homologation N°

ST - - 009

Extension N°

02/02 VO

VO

FICHE D'EXTENSION D'HOMOLOGATION POUR DISPOSITIFS AERODYNAMIQUES EN SUPERTOURISME
HOMOLOGATION EXTENSION FORM FOR AERODYNAMIC DEVICES IN SUPER TOURING

Homologation valable à partir du
Homologation valid as from

01 AVR. 1995

A) Voiture vue de 3/4 avant
Car seen from 3/4 front



B) Voiture vue de 3/4 arrière
Car seen from 3/4 rear



9. CARROSSERIE / BODYWORK

XVI) DISPOSITIF AVANT DEPOSE ET VU DE FACE AVEC DIMENSIONS DES OUVERTURES :
DISMOUNTED FRONT DEVICE SEEN FROM FRONT WITH DIMENSIONS OF OPENINGS:

Tolerances +/- 1%

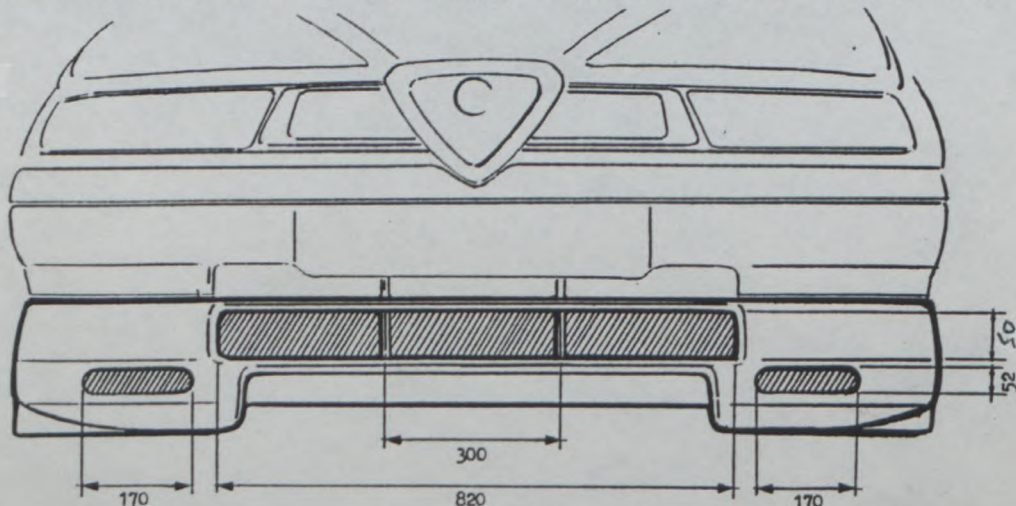

FEDERATION INTERNATIONALE DE L'AUTOMOBILE

8, place de la Concorde, 75008 Paris
Services Administratifs :
2 bis rue Boissy d'Anglas, 75008 Paris

XVIII) DISPOSITIF AVANT DEPOSE ET VU DE COTE AVEC DIMENSIONS DES OUVERTURES :
DISMOUNTED FRONT DEVICE IN SIDE VIEW WITH DIMENSIONS OF OPENINGS:

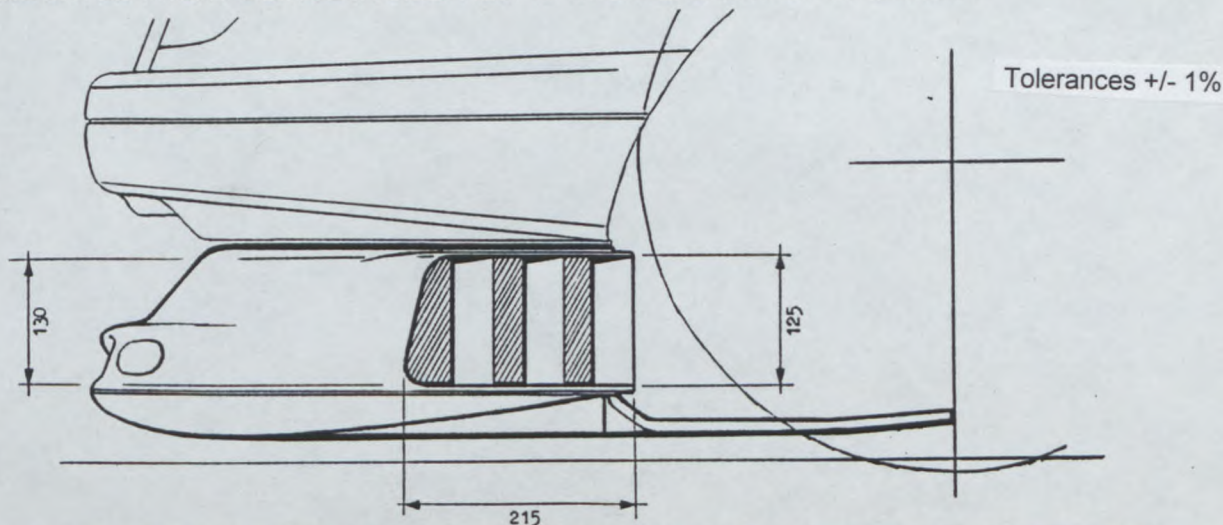

XXIII) DISPOSITIF AVANT EN PLACE ET VU DE FACE :
MOUNTED FRONT DEVICE SEEN FROM FRONT:



XXIV) DISPOSITIF AVANT EN PLACE ET VU DE COTE :
MOUNTED FRONT DEVICE IN SIDE VIEW:



FEDERATION INTERNATIONALE
DE L'AUTOMOBILE

8, place de la Concorde, 75008 Paris

Services Administratifs :

8 bis, rue Boissy d'Anglas, 75008 Paris

XVII) DISPOSITIF ARRIERE EN PLACE
ET VU DE COTE :
MOUNTED REAR DEVICE IN SIDE VIEW:



XIX) SECTION DU DISPOSITIF ARRIERE AU
NIVEAU DE L'AXE LONGITUDINAL DE LA
VOITURE :
SECTION OF REAR DEVICE AT CAR'S
CENTERLINE LEVEL:

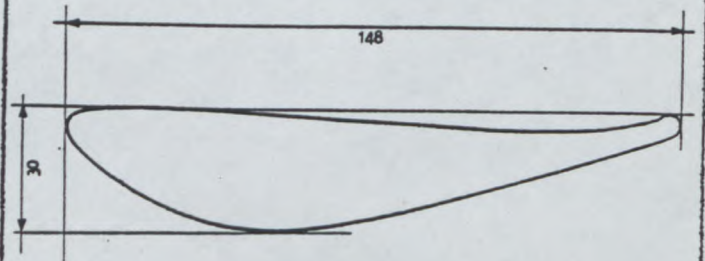

XX) DISPOSITIF ARRIERE EN PLACE ET VU DE DESSUS :
MOUNTED REAR DEVICE SEEN FROM ABOVE:



XXI) DISPOSITIF ARRIERE DEPOSE ET
VU DE COTE :
DISMOUNTED REAR DEVICE IN SIDE VIEW:



FEDERATION INTERNATIONALE
DE L'AUTOMOBILE

8, place de la Concorde, 75008 Paris

Services Administratifs :

8 bis, rue Boissy d'Anglas, 75008 Paris

Marque
Make

ALFA ROMEO

Modèle
Model

155 (M. Y. 1995)

ST - - 009

02/02 V0

XXII) DISPOSITIF ARRIERE DEPOSE ET VU DE DESSUS :
DISMOUNTED REAR DEVICE SEEN FROM ABOVE:

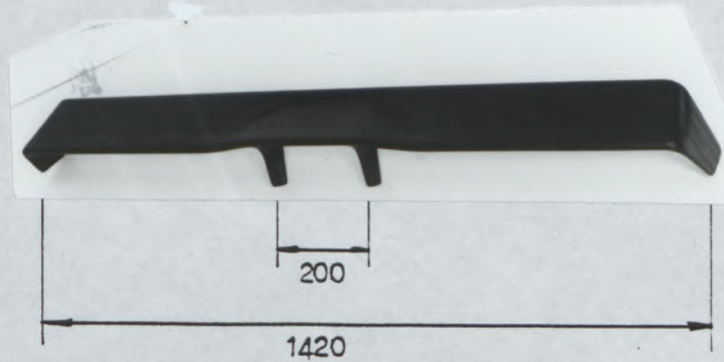

Tolerances +/- 1%

902. Extérieur : p) Angle entre dispositif arrière et carrosserie $11^{\circ} \pm 1^{\circ}$
Exterior: Angle between rear device and bodywork

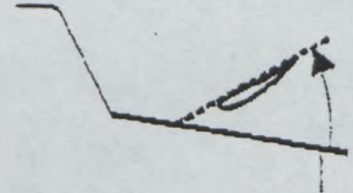

INFORMATIONS COMPLEMENTAIRES / COMPLEMENTARY INFORMATION :

902. Extérieur - Esterno

- p) Angle entre dispositif arrière et carrosserie
Angolo tra alettone posteriore e carrozzeria
- mesuré au niveau de l'axe longitudinal de la voiture;
le profil est variable
 - misurato a livello dell'asse longitudinale della vettura;
il profilo é variabile

* Toleran	
- Dimen	± 2 mm.
Dimen	± 3 mm.
- Dimen	± 4 mm.
Dimen	± 6 mm.

FEDERATION INTERNATIONALE
DE L'AUTOMOBILE

8, place de la Concorde, 75008 Paris

Services Administratifs :

8 bis, rue Boissy d'Anglas 75008 Paris

Marque
Make

ALFA ROMEO

Modèle
Model

155 (M. Y. 1995)

ST - - 009

02/02 V0

INFORMATIONS COMPLEMENTAIRES / COMPLEMENTARY INFORMATION :

9. CARROSSERIE - CARROZZERIA

Dispositif avant déposé et vu de dessous

Dispositivo anteriore depositato e visto di sotto

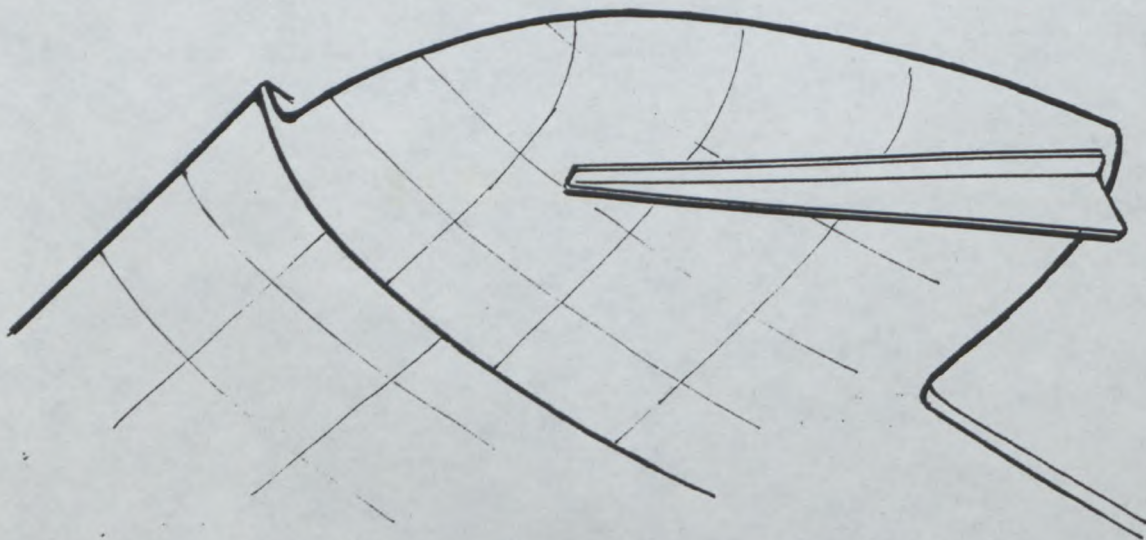

FEDERATION INTERNATIONALE
DE L'AUTOMOBILE

8, place de la Concorde, 75008 Paris

Services Administratifs :

8 bis rue Boissy d'Anglas, 75008 Paris



AUTOMOBILE CLUB D'ITALIA
COMMISSIONE SPORTIVA AUTOMOBILISTICA ITALIANA
FEDERATION INTERNATIONALE DE L'AUTOMOBILE

Homologation No

S T - 009

Groupe
Group

~~A/B/N/T1~~ Supertourisme
Supertouring

Extension No

03/01ER

FICHE D'EXTENSION D'HOMOLOGATION
FORM OF HOMOLOGATION EXTENSION

- | | |
|---|--|
| <input type="checkbox"/> ES Evolution sportive du type / Sporting evolution of the type | <input type="checkbox"/> VO Variante option / Option variant |
| <input type="checkbox"/> ET Evolution normale du type / Normal evolution of the type | <input checked="" type="checkbox"/> ER Erratum / Erratum |
| <input type="checkbox"/> VF Variante de fourniture / Supply variant | |

Véhicule: Constructeur ALFA ROMEO Modèle et type 155 (M. Y. 1995)
 Vehicle: Manufactureur ALFA ROMEO Model and type 155 (M. Y. 1995)

Homologation valable à partir du 01 MARS 1996
 Homologation valid as from 01 MARS 1996

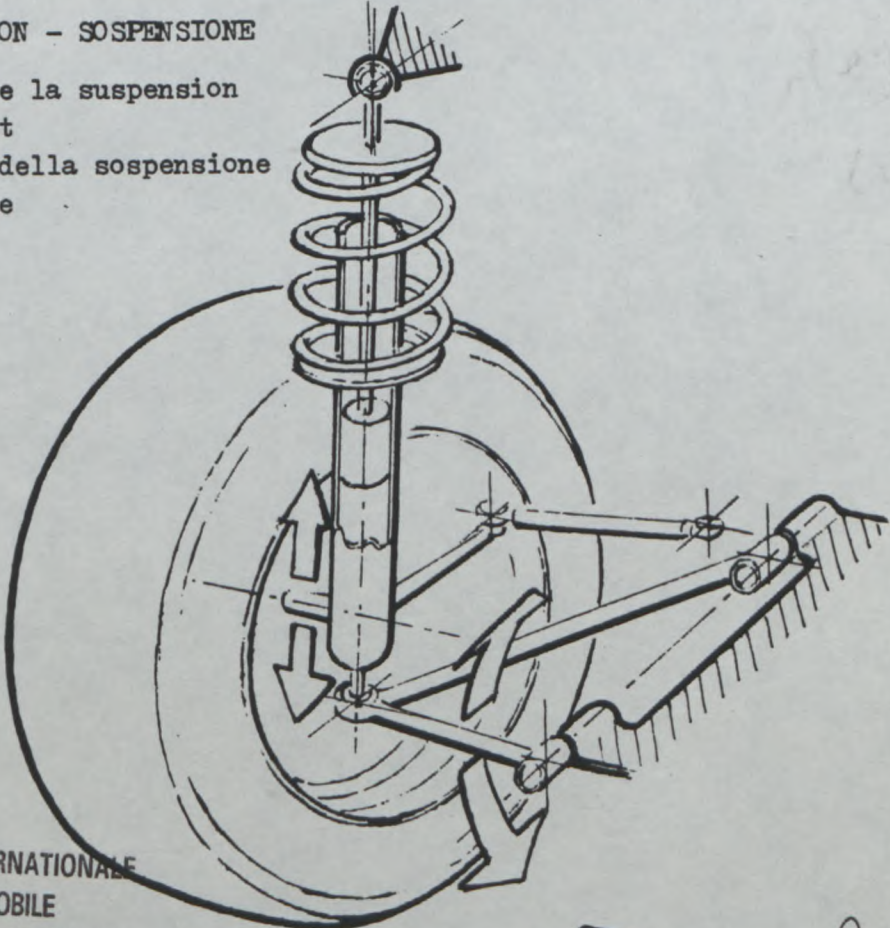
Page ou ext. Page or ext.	Article Article	Description Description
pag. 5	7.	<p>SUSPENSION - SOSPENSIONE</p> <p>Dessin de la suspension à l'avant Disegno della sospensione anteriore</p>  <p>FEDERATION INTERNATIONALE DE L'AUTOMOBILE 8, place de la Concorde, 75008 Paris Services Administratifs : 8 bis, rue Boissy d'Anglas, 75008 Paris</p>

Marque
Make

ALFA ROMEO

Modèle
Model

155 (M. Y. 1995)

Homologation No

ST - 009

Extension No

03/01ER

Page ou ext.
Page or ext.

Article
Article

Description
Description

pag. 5

7.

SUSPENSION - SOSPENSIONE

Dessin de la suspension à l'arrière
Disegno della sospensione posteriore

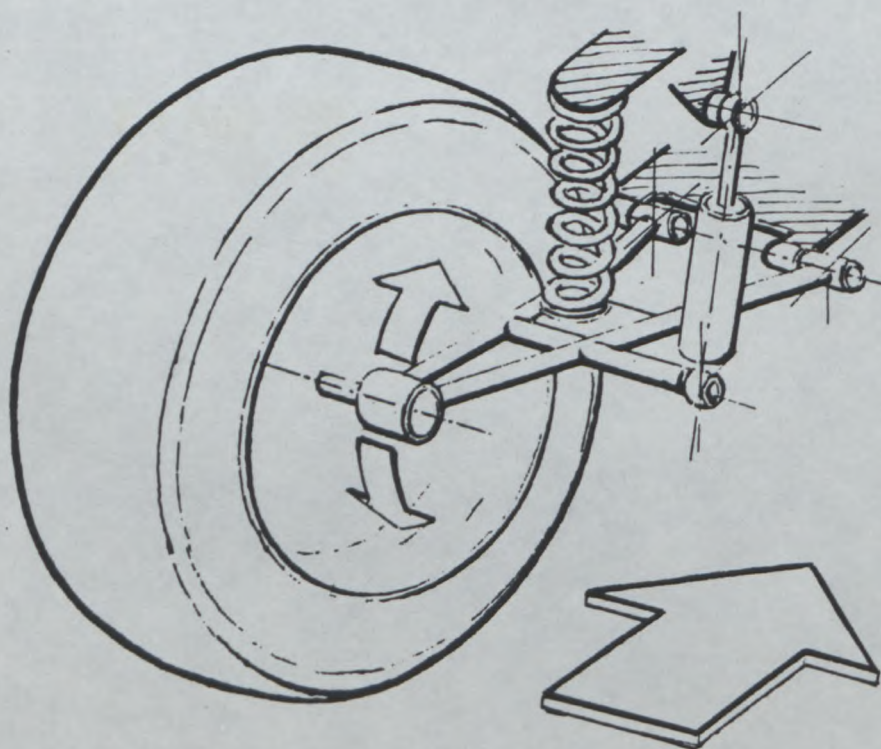

FEDERATION INTERNATIONALE
DE L'AUTOMOBILE

8, place de la Concorde, 75008 Paris

Services Administratifs :

8 bis, rue Boissy d'Anglas, 75008 Paris



AUTOMOBILE CLUB D'ITALIA
COMMISSIONE SPORTIVA AUTOMOBILISTICA ITALIANA
FEDERATION INTERNATIONALE DE L'AUTOMOBILE

Homologation No

ST - 009

Groupe
Group

~~A/B/N/T1~~ / **Supertourisme**
Supertouring

Extension No

04/03VO

FICHE D'EXTENSION D'HOMOLOGATION
FORM OF HOMOLOGATION EXTENSION

- ES Evolution sportive du type / Sporting evolution of the type VO Variante option / Option variant
 ET Evolution normale du type / Normal evolution of the type ER Erratum / Erratum
 VF Variante de fourniture / Supply variant

Véhicule: Constructeur ALFA ROMEO Modèle et type 155 (M. Y. 1995)
 Vehicle: Manufactureur _____ Model and type _____

Homologation valable à partir du 01 MARS 1996
 Homologation valid as from _____

Page ou ext. Page or ext.	Article Article	Description Description
pag. 6	9. 901.	CARROSSERIE - CARROZZERIA Intérieur Interno d) Sièges Sedili - Points d'attaques renforcés Punti di attacco rinforzati

PHOTO No 1 /96

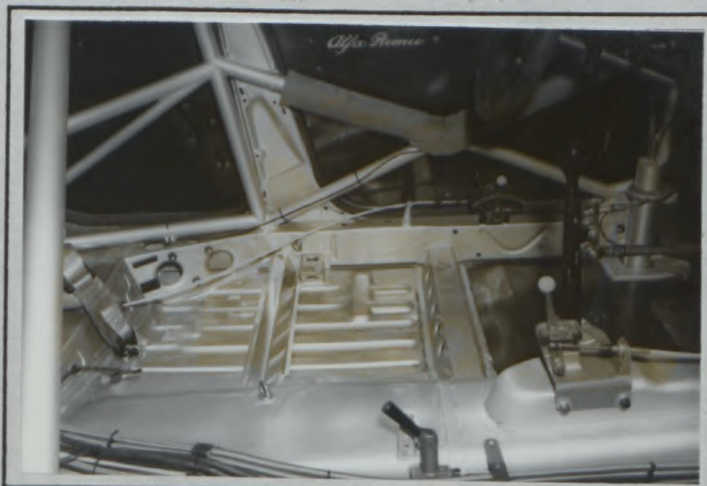
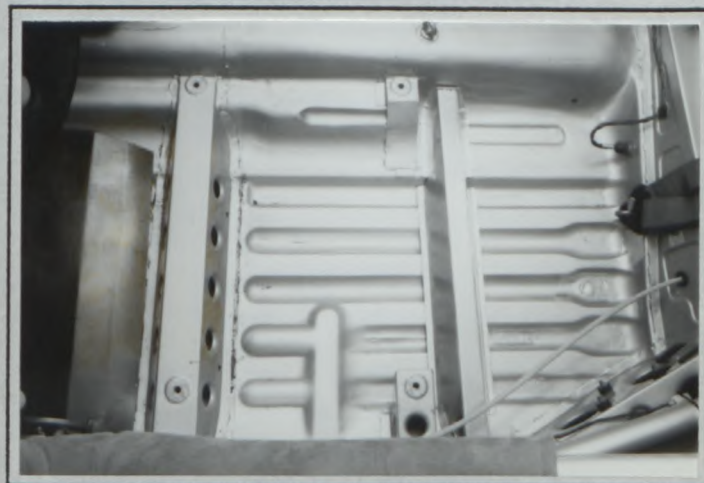

PHOTO No 2 /96



© FISA - FC - 1990 - 01001FB10.90

**FEDERATION INTERNATIONALE
DE L'AUTOMOBILE**

8, place de la Concorde, 75008 Paris
Services Administratifs :

R bis, rue Boissy d'Anglas, 75008 Paris



AUTOMOBILE CLUB D'ITALIA
COMMISSIONE SPORTIVA AUTOMOBILISTICA ITALIANA
FEDERATION INTERNATIONALE DE L'AUTOMOBILE

Homologation N°

ST - 009

Extension N°

05 / 04 VO

VO Supertourisme
 Supertouring

FICHE D'EXTENSION D'HOMOLOGATION POUR DISPOSITIFS AERODYNAMIQUES EN SUPERTOURISME
HOMOLOGATION EXTENSION FORM FOR AERODYNAMIC DEVICES IN SUPER TOURING

Homologation valable à partir du 01 MARS 1996
 Homologation valid as from _____

Véhicule : Constructeur ALFA ROMEO Modèle et type 155 (M. Y. 1995)
 Vehicle: Manufacturer _____ Model and type _____

A) Voiture vue de 3/4 avant
 Car seen from 3/4 front



B) Voiture vue de 3/4 arrière
 Car seen from 3/4 rear



9. CARROSSERIE / BODYWORK

XVI) DISPOSITIF AVANT DEPOSE ET VU DE FACE AVEC DIMENSIONS DES OUVERTURES :
 DISMOUNTED FRONT DEVICE SEEN FROM FRONT WITH DIMENSIONS OF OPENINGS:

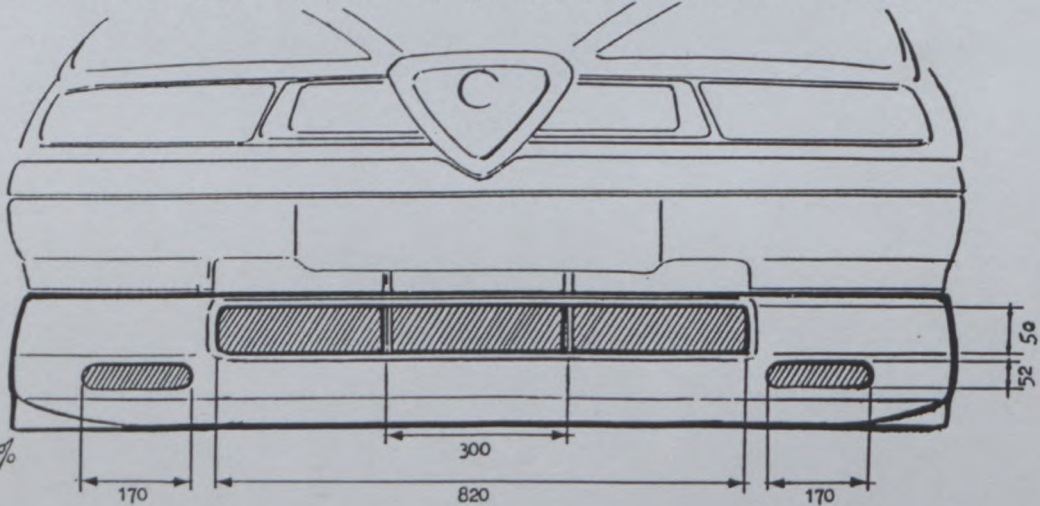

Tolerance +/- 1%

**FEDERATION INTERNATIONALE
 DE L'AUTOMOBILE**

8, place de la Concorde, 75008 Paris

Services Administratifs :

8 bis, rue Boissy d'Anglas, 75008 Paris

Marque
Make

ALFA ROMEO

Modèle
Model

155 (M. Y. 1995)

Homologation N°

S T - 009

Extension N°

05 / 04 V0

XVIII) DISPOSITIF AVANT DEPOSE ET VU DE COTE AVEC DIMENSIONS DES OUVERTURES :
DISMOUNTED FRONT DEVICE IN SIDE VIEW WITH DIMENSIONS OF OPENINGS:

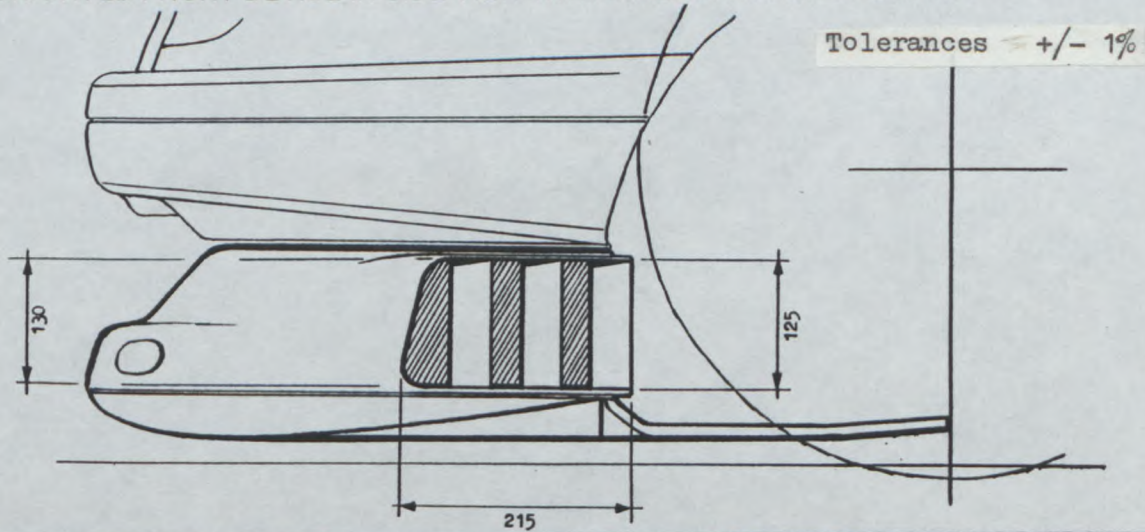

XXIII) DISPOSITIF AVANT EN PLACE ET VU DE FACE :
MOUNTED FRONT DEVICE SEEN FROM FRONT:



XXIV) DISPOSITIF AVANT EN PLACE ET VU DE COTE :
MOUNTED FRONT DEVICE IN SIDE VIEW:



FEDERATION INTERNATIONALE
DE L'AUTOMOBILE

8, place de la Concorde, 75008 Paris

Services Administratifs:

8 bis. rue Boissy d'Anglas, 75008 Paris

Marque
Make

ALFA ROMEO

Modèle
Model

155 (M. Y. 1995)

Homologation N°

S T - 009

Extension N°

05/04 V0

XVII) DISPOSITIF ARRIERE EN PLACE
ET VU DE COTE :
MOUNTED REAR DEVICE IN SIDE VIEW:



XIX) SECTION DU DISPOSITIF ARRIERE AU
NIVEAU DE L'AXE LONGITUDINAL DE LA
VOITURE :
SECTION OF REAR DEVICE AT CAR'S
CENTERLINE LEVEL:

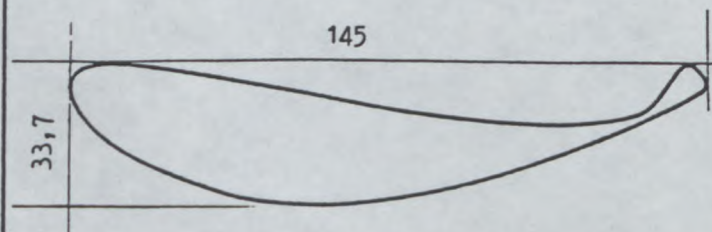

Tolerance +/- 1%

XX) DISPOSITIF ARRIERE EN PLACE ET VU DE DESSUS :
MOUNTED REAR DEVICE SEEN FROM ABOVE:



XXI) DISPOSITIF ARRIERE DEPOSE ET
VU DE COTE :
DISMOUNTED REAR DEVICE IN SIDE VIEW:



FEDERATION INTERNATIONALE
DE L'AUTOMOBILE

8, place de la Concorde, 75008 Paris

Services Administratifs :

8 bis, rue Boissy d'Anglas, 75008 Paris

Marque
Make

ALFA ROMEO

Modèle
Model

155 (M. Y. 1995)

Homologation N°

S T - 009

Extension N°

05 / 04 V0

XXII) DISPOSITIF ARRIERE DEPOSE ET VU DE DESSUS :
DISMOUNTED REAR DEVICE SEEN FROM ABOVE :

Tolerances $\pm 1\%$

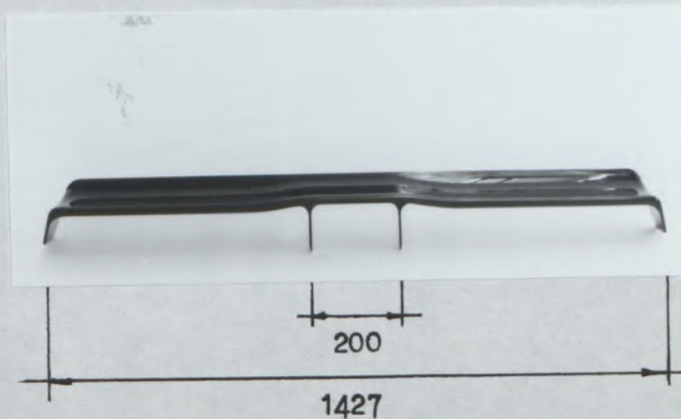

902. Extérieur : p) Angle entre dispositif arrière et carrosserie
Exterior: Angle between rear device and bodywork

$8^\circ \pm 1^\circ$



INFORMATIONS COMPLEMENTAIRES / COMPLEMENTARY INFORMATION :

902. Extérieur - Esterno

p) Angle entre dispositif arrière et carrosserie
Angolo tra alettone posteriore e carrozzeria

- mesuré au niveau de l'axe longitudinal de la voiture;
le profil est variable
- misurato a livello dell'asse longitudinale della vettura;
il profilo é variabile

FEDERATION INTERNATIONALE
DE L'AUTOMOBILE

8, place de la Concorde, 75008 Paris

Services Administratifs :

8 bis, rue Boissy d'Anglas, 75008 Paris

Marque
Make

ALFA ROMEO

Modèle
Model

155 (M. Y. 1995)

Homologation N°

S T - 009

Extension N°

05 / 0 4 V0

INFORMATIONS COMPLEMENTAIRES / COMPLEMENTARY INFORMATION :

9. CARROSSERIE - CARROZZERIA

Dispositif avant déposé et vu de dessous

Dispositivo anteriore depositato e visto di sotto

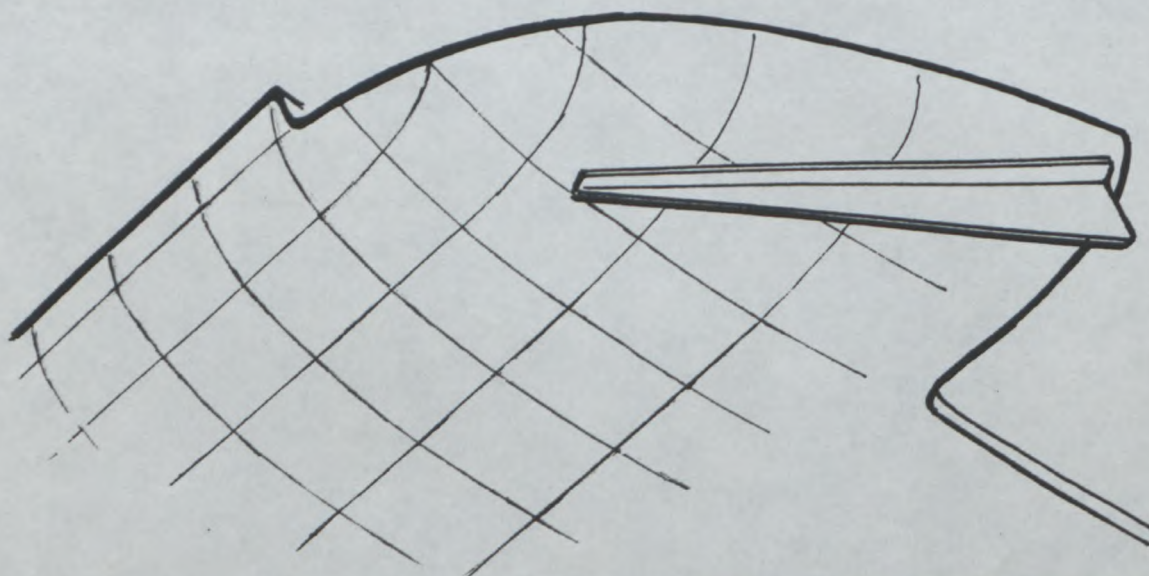

FEDERATION INTERNATIONALE
DE L'AUTOMOBILE

8, place de la Concorde, 75008 Paris

Services Administratifs :

8 bis, rue Boissy d'Anglas, 75008 Paris



AUTOMOBILE CLUB D'ITALIA
COMMISSIONE SPORTIVA AUTOMOBILISTICA ITALIANA
FEDERATION INTERNATIONALE DE L'AUTOMOBILE

Homologation N°

ST - 009

Extension N°

06 / 05 VO

VO **Supertourisme**
Supertouring

FICHE D'EXTENSION D'HOMOLOGATION POUR DISPOSITIFS AERODYNAMIQUES EN SUPERTOURISME
HOMOLOGATION EXTENSION FORM FOR AERODYNAMIC DEVICES IN SUPER TOURING

Homologation valable à partir du
 Homologation valid as from

01 MARS 1997

Véhicule : Constructeur
 Vehicle: Manufacturer

ALFA ROMEO

Modèle et type
 Model and type

155 (M. Y. 1995)

A) Voiture vue de 3/4 avant
 Car seen from 3/4 front

B) Voiture vue de 3/4 arrière
 Car seen from 3/4 rear

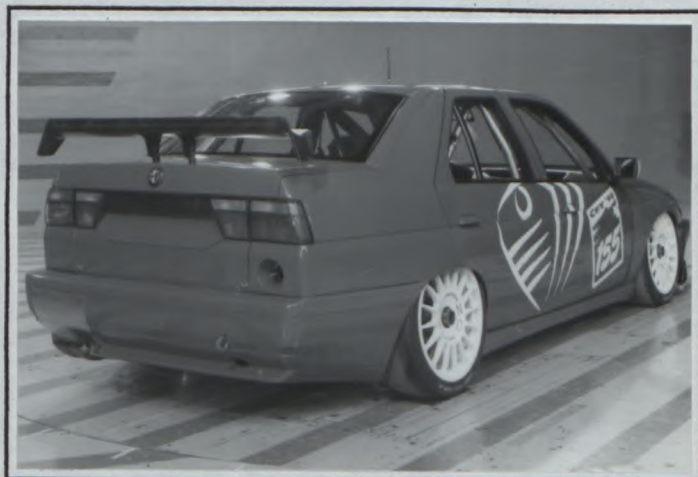

9. CARROSSERIE / BODYWORK

XVI) DISPOSITIF AVANT DEPOSE ET VU DE FACE AVEC DIMENSIONS DES OUVERTURES :
 DISMOUNTED FRONT DEVICE SEEN FROM FRONT WITH DIMENSIONS OF OPENINGS:

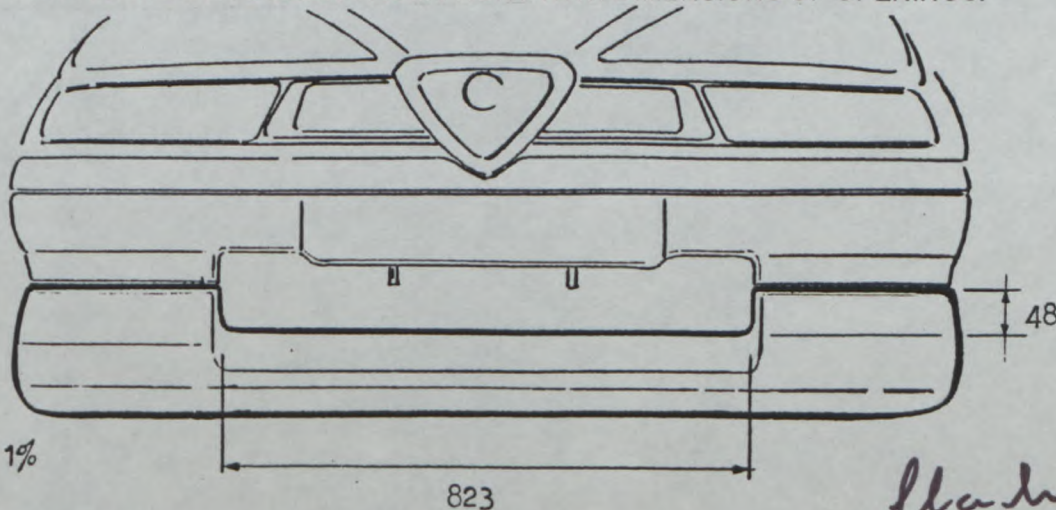

Tolerance +/- 1%

823

48

fla hys

FEDERATION INTERNATIONALE
 DE L'AUTOMOBILE

8, place de la Concorde, 75008 Paris

Services Administratifs :

8 bis, rue Boissy d'Anglas, 75008 Paris

Marque
Make

ALFA ROMEO

Modèle
Model

155 (M. Y. 1995)

Homologation N°

S T - 009

Extension N°

06/05V0

XVIII) DISPOSITIF AVANT DEPOSE ET VU DE COTE AVEC DIMENSIONS DES OUVERTURES :
DISMOUNTED FRONT DEVICE IN SIDE VIEW WITH DIMENSIONS OF OPENINGS:

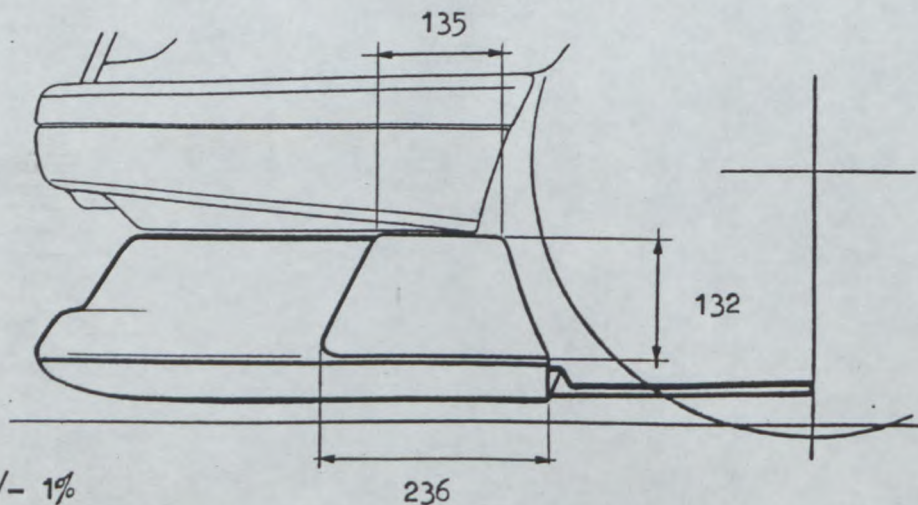

XXIII) DISPOSITIF AVANT EN PLACE ET VU DE FACE :
MOUNTED FRONT DEVICE SEEN FROM FRONT:



XXIV) DISPOSITIF AVANT EN PLACE ET VU DE COTE :
MOUNTED FRONT DEVICE IN SIDE VIEW:



FEDERATION INTERNATIONALE
DE L'AUTOMOBILE

8, place de la Concorde, 75008 Paris

Services Administratifs :

8 bis, rue Boissy d'Anglas, 75008 Paris

XVII) DISPOSITIF ARRIERE EN PLACE
ET VU DE COTE :
MOUNTED REAR DEVICE IN SIDE VIEW:



XIX) SECTION DU DISPOSITIF ARRIERE AU
NIVEAU DE L'AXE LONGITUDINAL DE LA
VOITURE :
SECTION OF REAR DEVICE AT CAR'S
CENTERLINE LEVEL:

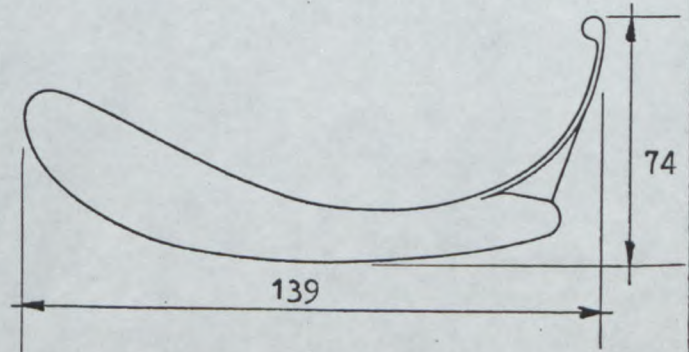

Tolerance +/- 1%

XX) DISPOSITIF ARRIERE EN PLACE ET VU DE DESSUS :
MOUNTED REAR DEVICE SEEN FROM ABOVE:



XXI) DISPOSITIF ARRIERE DEPOSE ET
VU DE COTE :
DISMOUNTED REAR DEVICE IN SIDE VIEW:



Marque
Make

ALFA ROMEO

Modèle
Model

155 (M. Y. 1995)

Homologation N°

S T - 009

Extension N°

06 / 05 V0

XXII) DISPOSITIF ARRIERE DEPOSE ET VU DE DESSUS :
DISMOUNTED REAR DEVICE SEEN FROM ABOVE:

Tolerances $\pm 1\%$

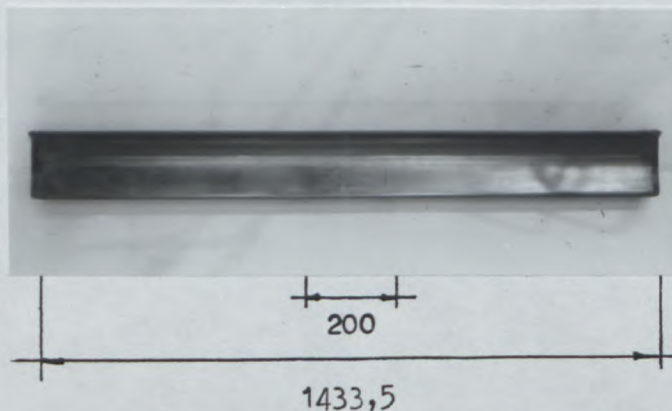

902. Extérieur : p) Angle entre dispositif arrière et carrosserie $25^{\circ} 30' \pm 1^{\circ}$.
Exterior: Angle between rear device and bodywork

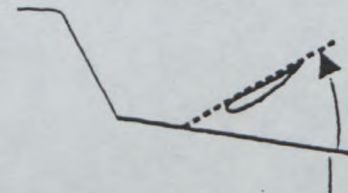

INFORMATIONS COMPLEMENTAIRES / COMPLEMENTARY INFORMATION :

902. Extérieur - Esterno

- p) Angle entre dispositif arrière et carrosserie
Angolo tra alettone posteriore e carrozzeria
- mesuré au niveau de l'axe longitudinal de la voiture;
 - misurato a livello dell'asse longitudinale della vettura;

FEDERATION INTERNATIONALE
DE L'AUTOMOBILE

8, place de la Concorde, 75008 Paris

Services Administratifs :

8 bis, rue Boissy d'Anglas, 75008 Paris

Marcue
Make

ALFA ROMEO

Modèle
Model

155 (M. Y. 1995)

Homologation N°

S T - 009

Extension N°

06 / 05 V0

INFORMATIONS COMPLEMENTAIRES / COMPLEMENTARY INFORMATION :

9. CARROSSERIE - CARROZZERIA

Dispositif avant déposé et vu de dessous

Dispositivo anteriore depositato e visto di sotto

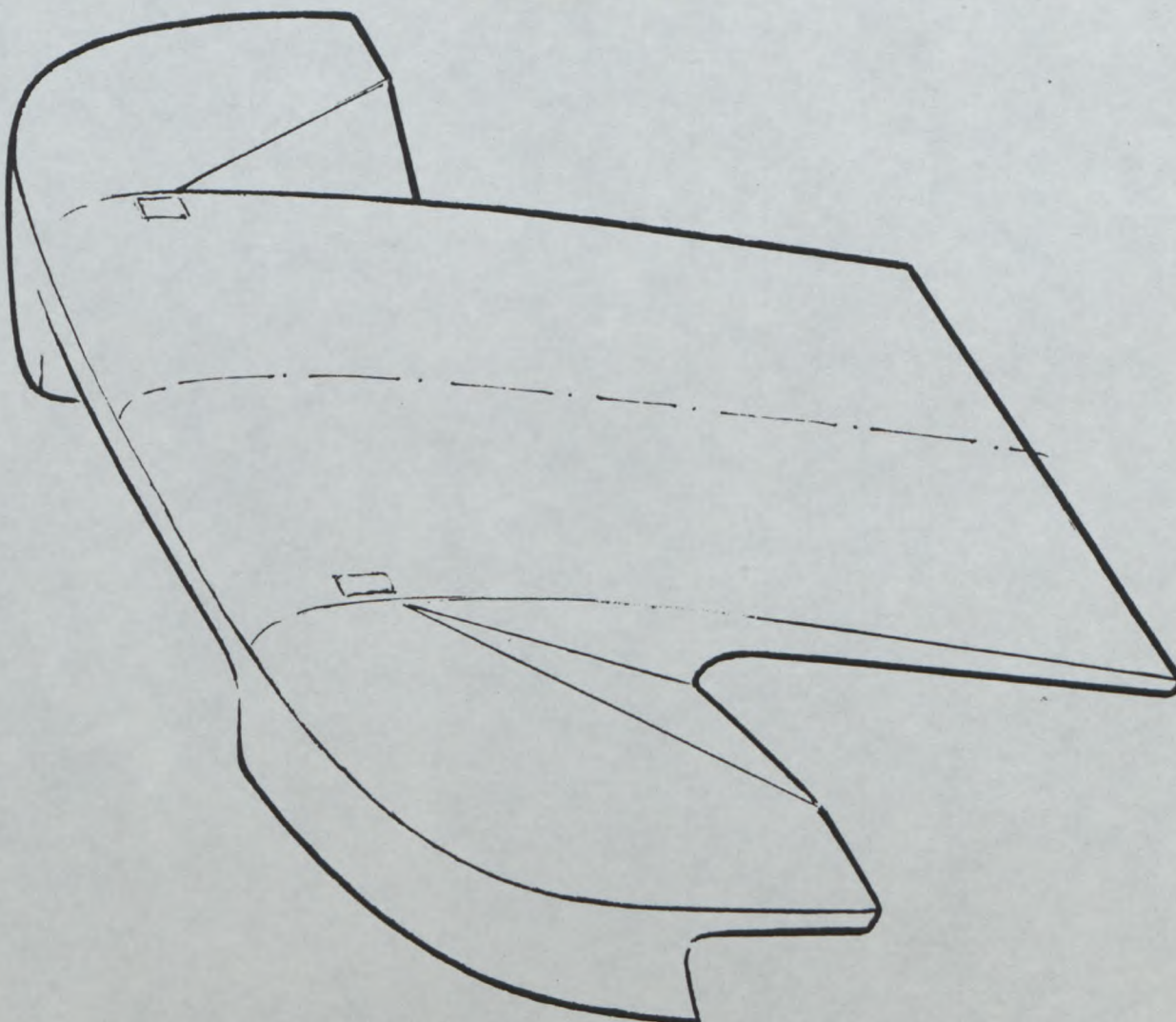

FEDERATION INTERNATIONALE
DE L'AUTOMOBILE

8, place de la Concorde, 75008 Paris

Services Administratifs :

8 bis, rue Boissy d'Anglas, 75008 Paris



FEDERATION INTERNATIONALE
DE L'AUTOMOBILE

ST - 009

Groupe ~~A/B/N/T1~~ Supertourisme
Group ~~A/B/N/T1~~ Supertouring

Extension No
07/06 VO

FICHE D'EXTENSION D'HOMOLOGATION POUR ARMATURE DE SECURITE
FORM OF HOMOLOGATION EXTENSION FOR SAFETY CAGE

VO Variante option / Option variant

Véhicule: Constructeur ALFA ROMEO Modèle et type 155 (M. Y. 1995)
Vehicle: Manufactureur ALFA ROMEO Model and type 155 (M. Y. 1995)

Homologation valable à partir du 01 JUL. 1997.
Homologation valid as from 01 JUL. 1997.

	Arceau principal Main rollbar	Entretoise longitudinale Longitudinal strut	Entretoise diagonale Diagonal Strut	Arceau avant Front rollbar
Matériau Material	acier - acciaio <i>25 Cr.No. 4 Norm</i>	acier - acciaio <i>25 Cr.No. 4 Norm</i>	acier - acciaio <i>25 Cr.No. 4 Norm</i>	acier - acciaio <i>25 Cr.No. 4 Norm</i>
Diamètre extérieur Exterior diameter	<u>40</u> mm	<u>40</u> mm	<u>40</u> mm	<u>40</u> mm
Epaisseur de paroi Wall thickness	<u>1,5</u> mm	<u>1,5</u> mm	<u>1,2</u> mm	<u>1,5</u> mm
Limite élastique Elastic limit	<u>49,0</u> daN/mm ²	<u>49,0</u> daN/mm ²	<u>49,0</u> daN/mm ²	<u>49,0</u> daN/mm ²
Résistance à la traction Tensile strength	<u>68,6</u> daN/mm ²	<u>68,6</u> daN/mm ²	<u>68,6</u> daN/mm ²	<u>68,6</u> daN/mm ²

Fabricant de l'armature ALFA ROMEO - NORD AUTO
Structure manufacturer ALFA ROMEO - NORD AUTO
N° 1 /97

Poids total y compris les fixations 48 kg
Total weight including fixations 48 kg

Armature complète hors de la voiture
Complete structure outside the car

Soudé à la coque (sans boulons)
Saldato alla scocca (senza bulloni)

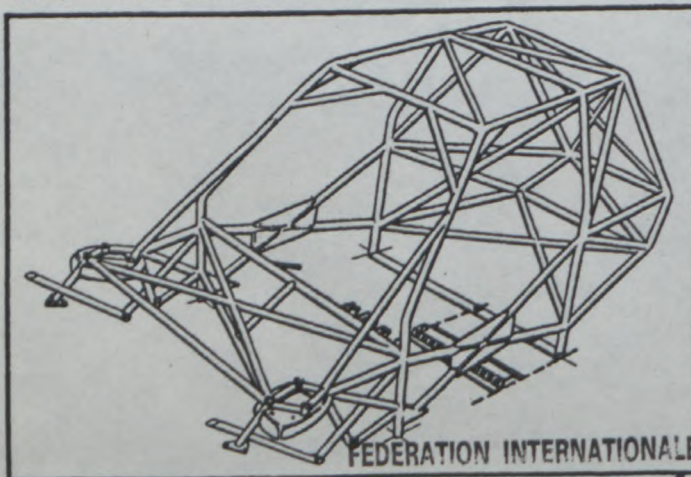

Nous attestons que la présente armature de sécurité répond aux dispositions de l'Annexe J de la FIA, en particulier en ce qui concerne ses implantations, ses connexions, et ses résistances aux contraintes.

We certify that the present safety structure complies with the conditions of the FIA Appendix J, in particular with regard to its attachments, its connections, and its stress resistances.

Signature du représentant du constructeur du véhicule
Signature of the car manufacturer representative

F.to Ing. S. Limone
F.to Ing. S. Limone

FEDERATION INTERNATIONALE
DE L'AUTOMOBILE
8, place de la Concorde, 75008 Paris
Services Administratifs :
8 bis, rue Boissy d'Anglas, 75008 Paris

Marque
Make

ALFA ROMEO

Modèle
Model

155 (M. Y. 1995)

Homologation No

ST - 009

Extension No

07/06W0

PHOTO No 1 /97



PHOTO No 2 /97



PHOTO No 3 /97

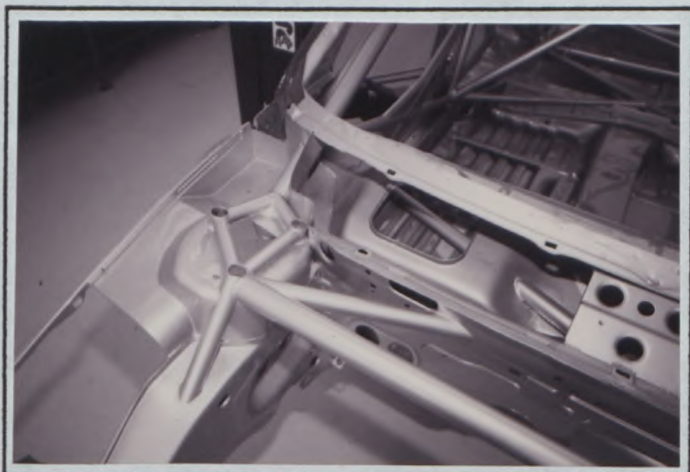

PHOTO No 4 /97



PHOTO No 5 /97

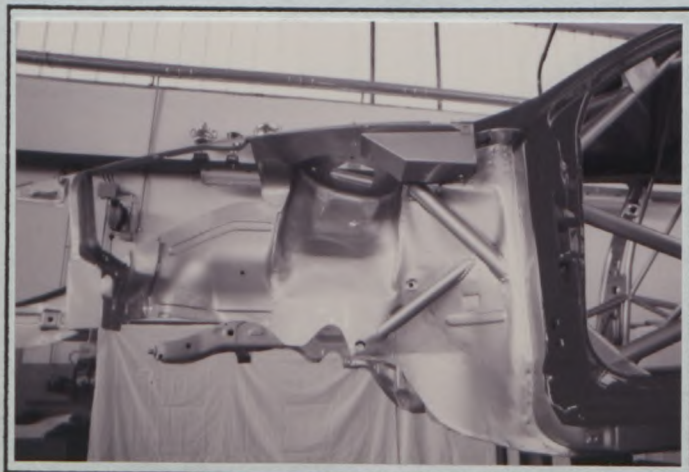
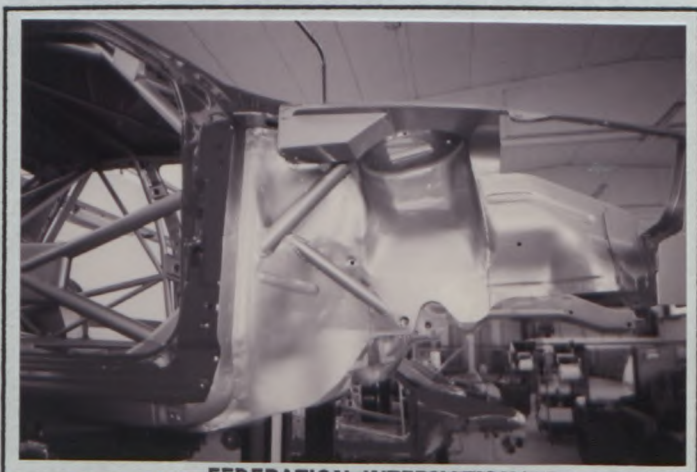

PHOTO No 6 /97



FEDERATION INTERNATIONALE
DE L'AUTOMOBILE

8, place de la Concorde, 75008 Paris

Services Administratifs :

8 bis, rue Boissy d'Anglas, 75008 Paris

Marque
Make

ALFA ROMEO

Modèle
Model

155 (M. Y. 1995)

Homologation No

ST - 009

Extension No

07 / 06 VO

PHOTO No 7 /97

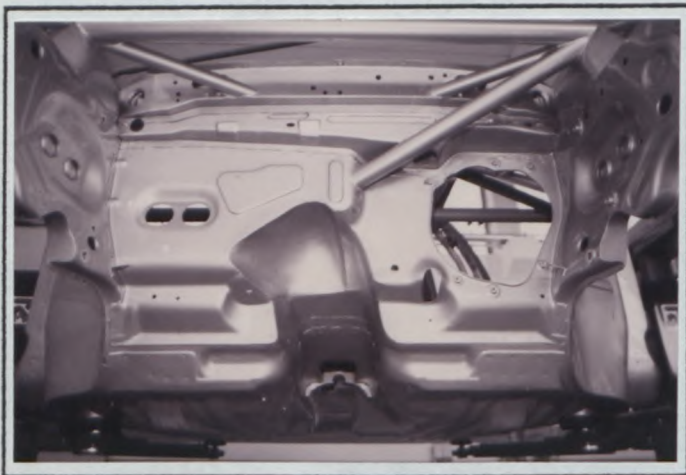

PHOTO No 8 /97

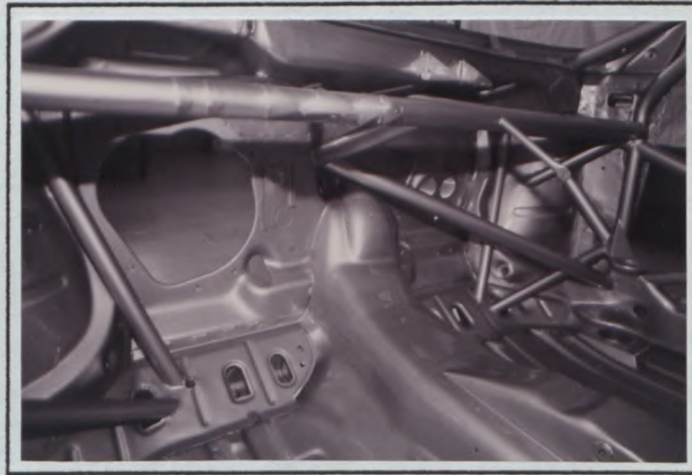

PHOTO No 9 /97

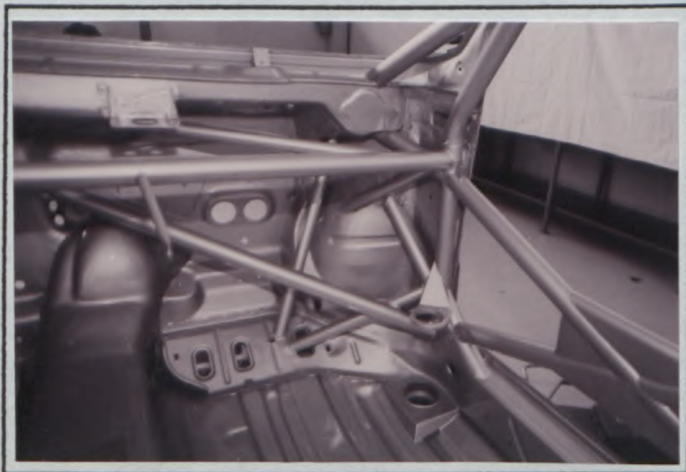

PHOTO No 10 /97



PHOTO No 11 /97



PHOTO No 12 /97

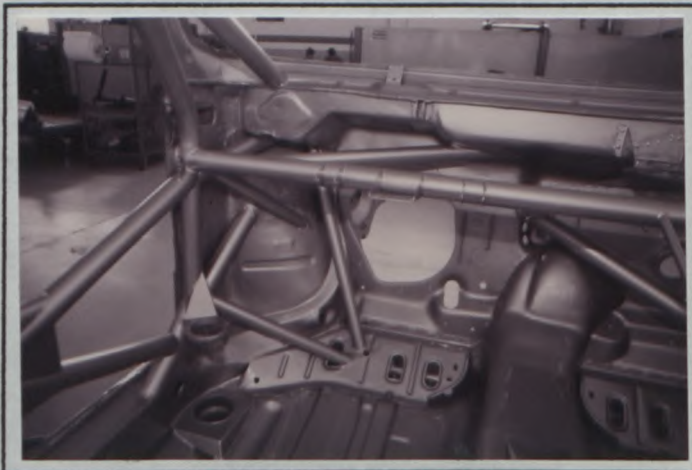

FEDERATION INTERNATIONALE
DE L'AUTOMOBILE

8, place de la Concorde, 75008 Paris

Services Administratifs :

8 bis, rue Boissy d'Anglas, 75008 Paris

Marque
Make

ALFA ROMEO

Modèle
Model

155 (M. Y. 1995)

Homologation No

ST - 009

Extension No

07/06 VO

PHOTO No 13 /97

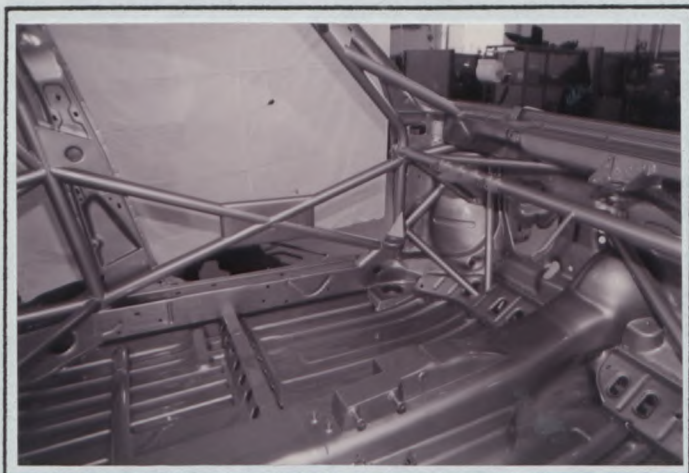

PHOTO No 14 /97

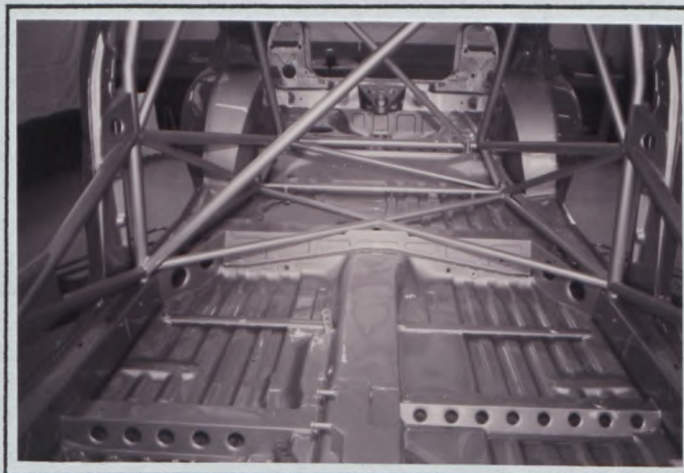

PHOTO No 15 /97

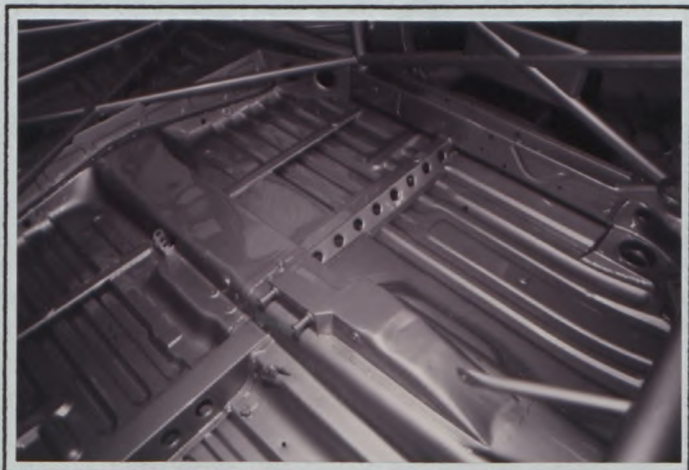

PHOTO No 16 /97



PHOTO No 17 /97



PHOTO No 18 /97

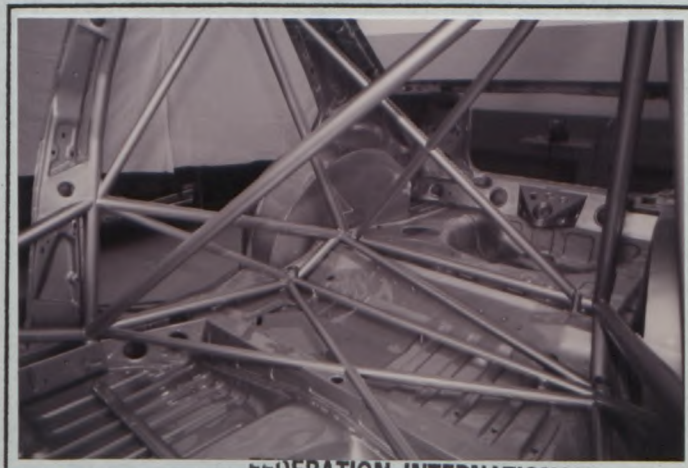

FEDERATION INTERNATIONALE
DE L'AUTOMOBILE

8, place de la Concorde, 75008 Paris

Services Administratifs :

8 bis, rue Boissy d'Anglas, 75008 Paris

Marque
Make

ALFA ROMEO

Modèle
Model

155 (M. Y. 1995)

Homologation No

ST - 009

Extension No

07 / 06 V0

PHOTO No 19 /97

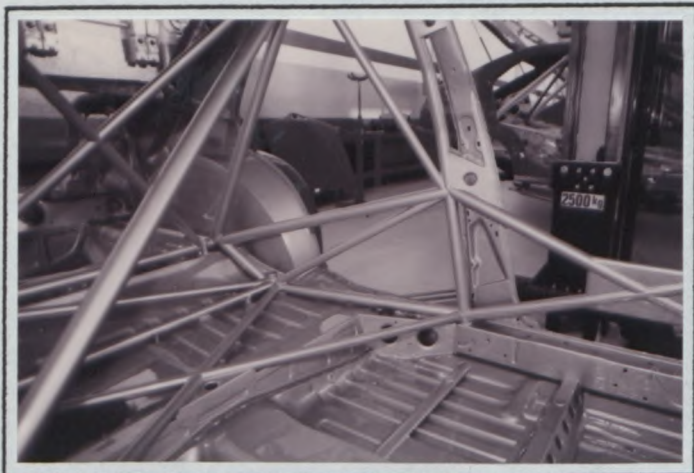

PHOTO No 20 /97



PHOTO No 21 /97

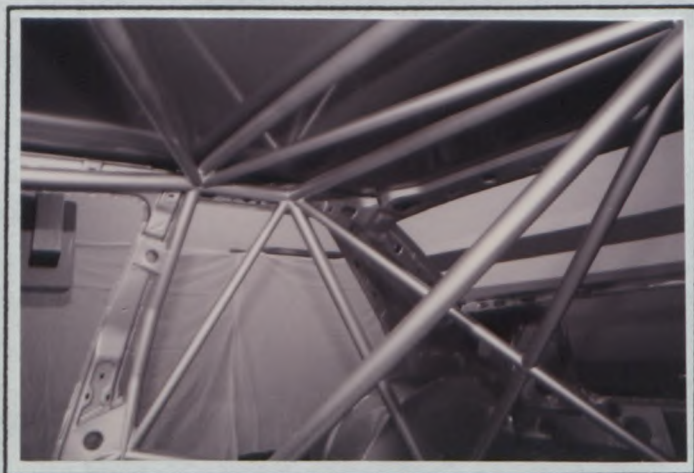

PHOTO No 22 /97

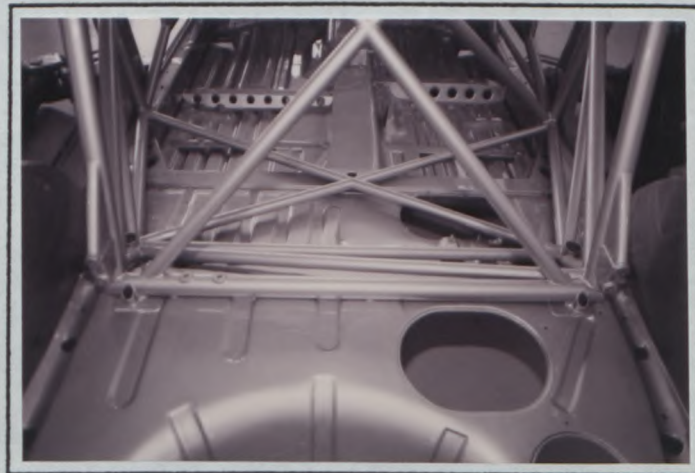
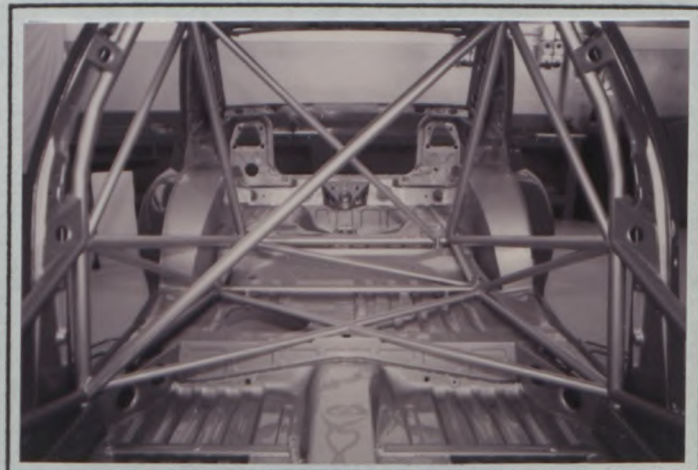

PHOTO No 23 /97



PHOTO No 24 /97



FEDERATION INTERNATIONALE
DE L'AUTOMOBILE

8, place de la Concorde, 75008 Paris
Services Administratifs :

8 bis, rue Boissy d'Anglas, 75008 Paris

Marque
Make

ALFA ROMEO

Modèle
Model

155 (M. Y. 1995)

Homologation No

ST - 009

Extension No

07/06V0

PHOTO No 25 /97

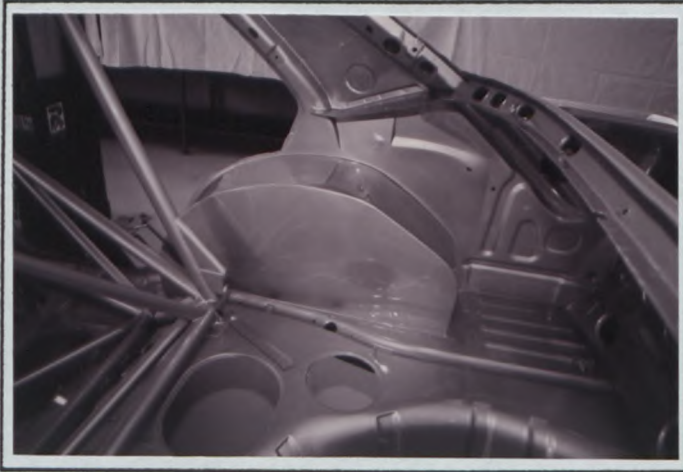

PHOTO No 26 /97

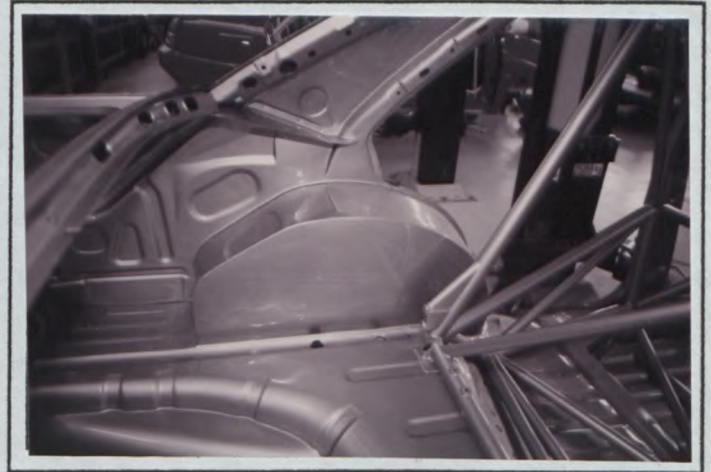

PHOTO No 27 /97



PHOTO No 28 /97



PHOTO No 29 /97



PHOTO No 30 /97



FEDERATION INTERNATIONALE
DE L'AUTOMOBILE

8, place de la Concorde, 75008 Paris

Services Administratifs :

8 bis, rue Boissy d'Anglas, 75008 Paris

Marque
Make

ALFA ROMEO

Modèle
Model

155 (M. Y. 1995)

ST - 009

07/06V0

INFORMATIONS COMPLEMENTAIRES / COMPLEMENTARY INFORMATION :

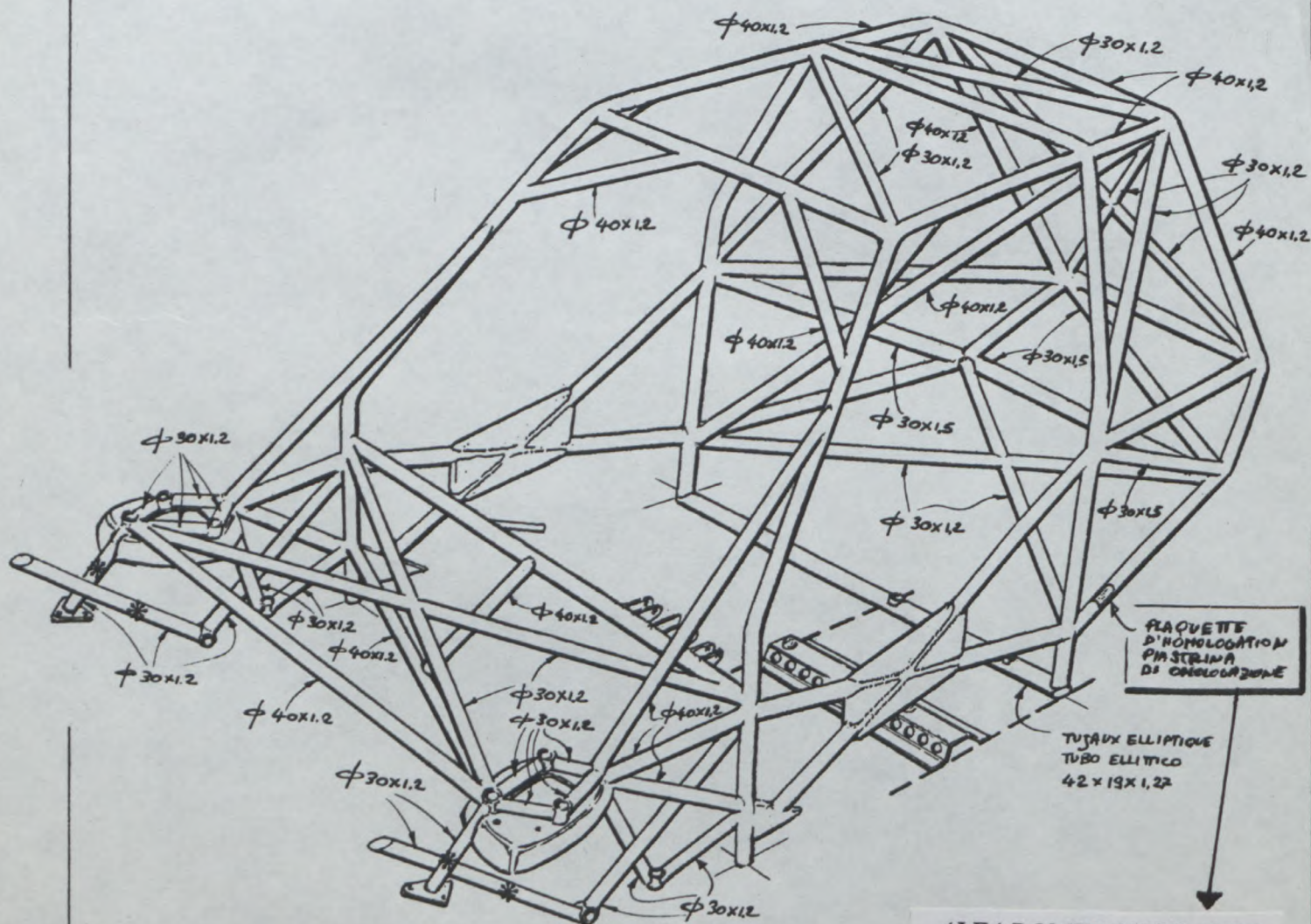
ALFA ROMEO NORDAUTO
N. 00 ____ data ____Tujaux sans indications
Tubi senza indicazioni40 x 1,5 mm.
40 x 1,5 mm.

- * support moteur
- * supporto motore

FEDERATION INTERNATIONALE
DE L'AUTOMOBILE

8, place de la Concorde, 75008 Paris

Services Administratifs :

8 bis, rue Boissy d'Anglas, 75008 Paris